

Vertical Format 0.123" 4-Character 5x5 Dot Matrix Serial Input Dot Addressable Intelligent Display® Devices

Lead (Pb) Free Product - RoHS Compliant

Standard Red	SCDV5540
Yellow	SCDV5541
Super-red	SCDV5542
Green	SCDV5543
High Efficiency Green	SCDV5544

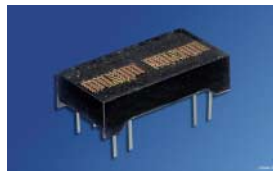

DESCRIPTION

The SCDV5540 (Red), SCDV5541 (Yellow), SCDV5542 (Super-red), SCDV5543 (Green), and SCDV5544 (High Efficiency Green) are four digit, dot addressable 5 x 5 dot matrix, serial input, alphanumeric Intelligent Display devices in a vertical format. The four digits are packaged in a rugged, high quality, optically transparent, plastic 14 pin DIP with 7.62 mm (0.3") pin spacing.

The on-board CMOS has a 100 bit RAM, one bit associated with one LED, each to generate User Defined Characters. In Power Down Mode, quiescent current is < 50 μ A.

The SCDV554X is designed for work with the serial port of most common microprocessors. Data is transferred into the display through the Serial Data Input (DATA), clocked by the Serial Data Clock (SDCLK), and enabled by the Load Input (LOAD).

The Clock I/O (CLK I/O) and Clock Select ($\overline{\text{CLKSEL}}$) pins offer the user the capability to supply a high speed external multiplex clock. This feature can minimize audio in-band interference for portable communication equipment or eliminate the visual synchronization effects found in high vibration environments such as avionics equipment.

FEATURES

- Vertical Format, Four 3.12 mm (0.123") 5 x 5 Dot Matrix Characters in Red, Yellow, Super-red, Green, or High Efficiency Green
- Optimum Display Surface Efficiency (display area to package ratio)
- High Speed Data Input Rate: 5.0 MHz
- ROMless Serial Input, Dot Addressable Display Ideal for User Defined Characters
- Built-in Decoders, Multiplexers and LED Drivers
- Readable from 1.8 meters (6.0 Feet)
- Wide Viewing Angle, X Axis $\pm 55^\circ$, Y Axis $\pm 55^\circ$
- Attributes:
 - 100 Bit RAM for User Defined Characters
 - Eight Dimming Levels
 - Power Down Model (< 250 μ W)
 - Hardware/Software Clear Functions
 - Lamp Test
 - Internal or External Clock
- 3.3 V Capability

SCDV5540, SCDV5541, SCDV5542, SCDV5543, SCDV5544

Ordering Information

Type	Color of Emission	Character Height mm (inch)	Ordering Code
SCDV5540	standard red	3.2 (0.123)	Q68000A8890
SCDV5541	yellow		Q68000A8891
SCDV5542	super-red		Q68000A8892
SCDV5543	green		Q68000A8893
SCDV5544	high efficiency green		Q68000A8894

Package Outlines

Dimensions in mm (inch)

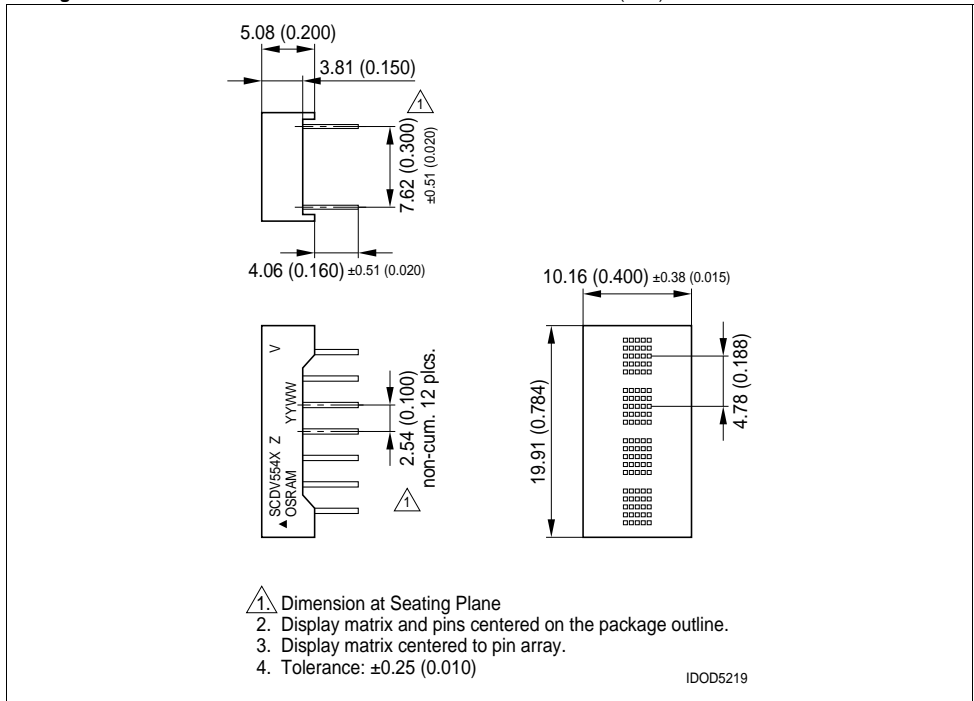

Maximum Ratings

Parameter	Symbol	Value	Unit
Operating temperature range	T_{op}	- 40 ... + 85	°C
Storage temperature range	T_{stg}	- 40 ... + 100	°C
DC Supply Voltage	V_{CC}	-0.5 to + 7.0	V
Input Voltage Levels Relative to GND		-0.5 to V_{CC} +0.5	V
Solder Temperature 1.59 mm (0.063") below seating plane, $t < 5.0$ s	T_s	260	°C
Relative Humidity		85	%
ESD (100 pF, 1.5 kΩ)	V_Z	2.0	kV
Input Current		± 100	mA
Maximum Number of LEDs on at 100% Brightness		64	
Maximum Power Dissipation		0.65	W

Optical Characteristics at 25°C

(V_{CC} =5.0 V at 100% brightness level, viewing angle: X axis ± 55°, Y axis ± 65°)

Description	Symbol	Values					Unit
		Red SCDV5540	Yellow SCDV5541	Super-red SCDV5542	Green SCDV5543	High Efficiency Green SCDV5544	
Luminous Intensity (min.)	I_v	0.48	1.80	1.80	1.80	2.10	mcd
Character Average (#displayed all digits) (typ.)		1.80	5.40	5.40	5.40	6.40	mdc
Peak Wavelength (typ.)	λ_{peak}	665	583	630	565	568	nm
Dominant Wavelength (typ.)	λ_{dom}	639	585	620	570	574	nm

Notes:

1. Dot to dot intensity matching at 100% brightness is 1.8:1.
2. Displays are binned for hue at 2.0 nm intervals.
3. Displays within a given intensity category have an intensity matching of 1.5:1 (max.).

Timing Diagram - Data Write Cycle

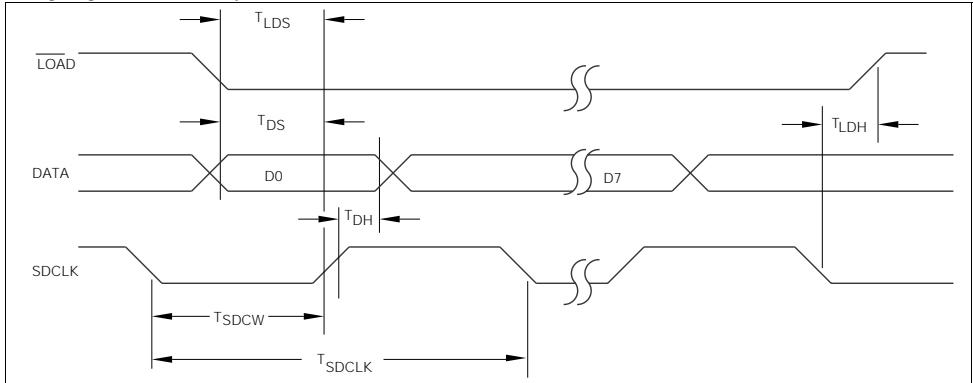

Timing Diagram - Instruction Cycle

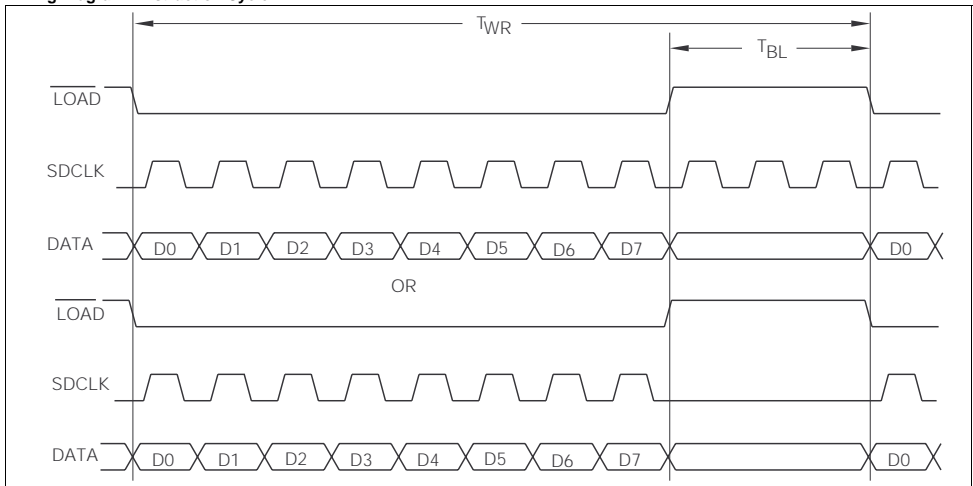

Switching Specifications

(over operating temperature range and $V_{CC}=4.5\text{ V to }5.5\text{ V}$)

Symbol	Description	Min.	Units	Symbol	Description	Min.	Units
T_{RC}	Reset Active Time	600	ns	T_{SDCLK}	Clock Period	200	ns
T_{LDS}	Load Setup Time	40	ns	T_{SDCW}	Clock Width	70	ns
T_{DS}	Data Setup Time	40	ns	T_{LDH}	Load Hold Time	0	ns
T_{DH}	Data Hold Time	20	ns	T_{WR}	Total Write Time	2.2	μs
T_{BL}	Time Between Loads	600	ns				

Note:

SDCLK duty cycle = 30% Min. and 50% Max.

Electrical Characteristics at 25°C

Parameter	Min.	Typ.	Max.	Units	Conditions
V_{CC}	4.5	5.0	5.5	V	—
I_{CC} (Pwr Dwn Mode) ⁴⁾	—	—	50	μA	$V_{CC}=5.0$ V, all inputs=0 V or V_{CC}
I_{CC} 4 digits 16 dots/character	—	100	140	mA	$V_{CC}=5.0$ V, “#” displayed in all 4 digits at 100% brightness at 25°C
I_{IL} Input current	—	—	-10	μA	$V_{CC}=5.0$ V, $V_{IN}=0$ (all inputs)
I_{IH} Input current	—	—	10	μA	$V_{CC}=V_{IN}=5.0$ V (all inputs)
V_{IH}	3.5	—	—	V	$V_{CC}=4.5$ V to 5.5 V
V_{IL}	—	—	1.5	V	$V_{CC}=4.5$ V to 5.5 V
I_{OH} (CLK I/O)	—	-8.9	—	mA	$V_{CC}=4.5$ V, $V_{OH}=2.4$ V
I_{OL} (CLK I/O)	—	1.6	—	mA	$V_{CC}=4.5$ V, $V_{OL}=0.4$ V
θ_{J-pin}	—	—	64	°C/W	—
F_{ext} External Clock Input Frequency	120	—	347	kHz	$V_{CC}=5.0$ V, CLKSEL=0
F_{osc} Internal Clock Input Frequency	120	—	347	kHz	$V_{CC}=5.0$ V, CLKSEL=1.0
Clock I/O Bus Loading	—	—	240	pF	—
Clock Out Rise Time	—	—	500	ns	$V_{CC}=4.5$ V, $V_{OH}=2.4$ V
Clock Out Fall Time	—	—	500	ns	$V_{CC}=4.5$ V, $V_{OH}=0.4$ V
FM, Digit	375	768	1086	Hz	—

Notes:

- 1) Contact Osram OS for 3.3 Volt operation.
- 2) Unused inputs must be tied high.
- 3) Peak current $\frac{5}{3} \times I_{CC}$.
- 4) External oscillator must be stopped if being used to maintain an $I_{CC} < 50$ μA.

Input/Output Circuits

Figures „Inputs“ and „Clock I/O“ show the input and output resistor/diode networks used for ESD protection and to eliminate substrate latch-up caused by input voltage over/under shoot.

Inputs

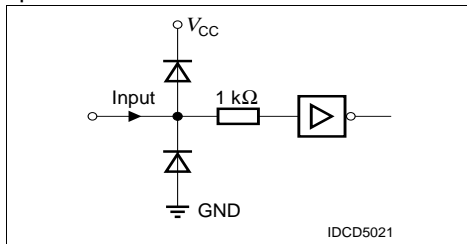

Clock I/O

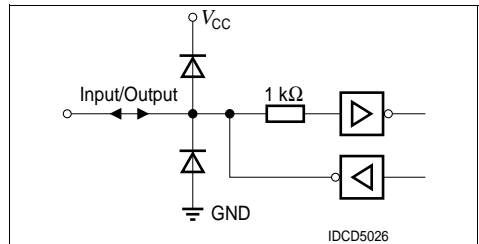

Top View

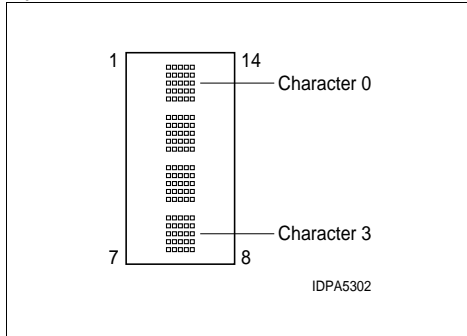

Pin Assignment

Pin	Function	Pin	Function
1	SDCLK	14	GND
2	LOAD	13	DATA
3	NP	12	V _{CC}
4	NP	11	V _{CC}
5	NP	10	V _{CC}
6	RST	9	CLKSEL
7	GND	8	CLK I/O

Dot Matrix Format

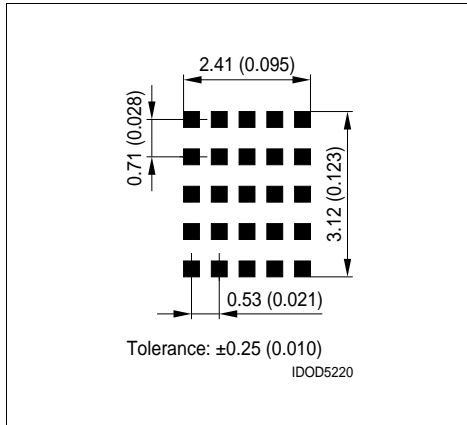

Pin Definitions

Pin	Function	Definitions
1	SDCLK	Loads data into the 8-bit serial data register on a low to high transition.
2	LOAD	Low input enables data clocking into 8-bit serial shift register. When LOAD goes high, the contents of 8-bit serial Shift Register will be decoded.
3	NP	No pin
4	NP	No pin
5	NP	No pin
6	RST	Asynchronous input, when low will clear the Multiplex Counter, User RAM and Data Register. Control Word Register is set to 100% brightness and the Address Register is set to select Digit 0. The display is blanked.
7	GND	Power supply ground
8	CLK I/O	Outputs master clock or inputs external clock.
9	CLKSEL	H=internal clock, L=external clock
10	V _{CC}	Power supply
11	V _{CC}	Power supply
12	V _{CC}	Power supply
13	DATA	Serial data input
14	GND	Power supply ground

Display Column and Row Format

	C0	C1	C2	C3	C4
Row 0	1	1	1	1	1
Row 1	0	0	1	0	0
Row 2	0	0	1	0	0
Row 3	0	0	1	0	0
Row 4	0	0	1	0	0

1= Display dot „ON“
0=Display dot „OFF“

Column Data Ranges

Row 0	00H to 1FH
Row 1	20H to 3FH
Row 2	40H to 5FH
Row 3	60H to 7FH
Row 4	80H to 9FH

SCDV5540, SCDV5541, SCDV5542, SCDV5543, SCDV5544

Operation of the SCDV554X

The SCDV554X display consists of a CMOS IC containing control logic and drivers for four 5 x 5 characters. These components are assembled in a compact plastic package.

Individual LED dot addressability allows the user great freedom in creating special characters or mini-icons. The User Definable Character Set Examples illustrate 200 different character and symbol possibilities.

The use of a serial data interface provides a highly efficient inter-

connection between the display and the mother board. The SCDV554X requires only 4 lines as compared to 15 for an equivalent four character parallel input part.

The on-board CMOS IC is the electronic heart of the display. The IC accepts decoded serial data, which is stored in the internal RAM. Asynchronously the RAM is read by the character multiplexer at a strobe rate that results in a flicker free display. Figure „SCDV554X Block Diagram“ (page 7) shows the three functional areas of the IC. These include: the input serial data register and control logic, a 100 bits two port RAM, and an internal multiplexer/display driver.

SCDV554X Block Diagram

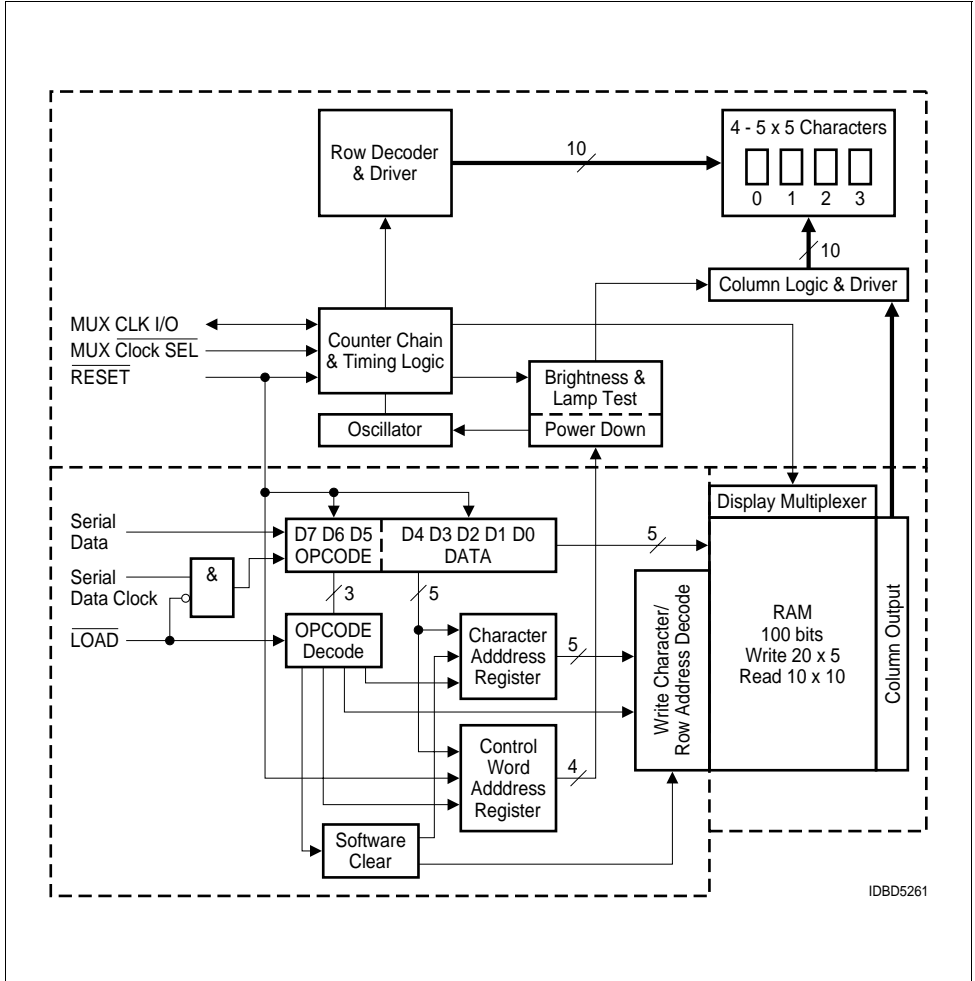

The following explains how to format the serial data to be loaded into the display. The user supplies a string of bit mapped decoded characters. The contents of this string is shown in Figure „Loading Serial Character Data a“ (page 8). Figure „Loading Serial Character Data b“ (page 8) shows that each character consist of six 8 bit words. The first word encodes the display character location and the succeeding five bytes are row data. The row data represents the status (On, Off) of individual column LEDs. Figure „Loading Serial Character Data c“ (page 8) shows that each 8 bit word is formatted to include a three bit Operational Code (OPCODE) defined by bits D7–D5 and five bits (D4–D0) representing Column Data, Character Address, or Control Word Data.

Figure „Loading Serial Character Data d“ (page 8) shows the sequence for loading the bytes of data. Bringing the LOAD line low enables the serial register to accept data. The shift action occurs on the low to high transition of the serial data clock (SDCLK). The least significant bit (D0) is loaded first. After eight clock pulses the LOAD line is brought high. With this transition the OPCODE is decoded. The decoded OPCODE directs D4–D0 to be latched in the Character Address register, stored in the RAM as Column data, or latched in the Control Word register. The control IC requires a minimum 600 ns delay between successive byte loads. As indicated in Figure „Loading Serial Character Data a“ (page 8), a total of 264 bits of data are required to load all eight characters into the display.

The Character Address Register bits, D4–D0 (Table „Load Character Address“ (page 9) and Row Address Register bits, D7–D5 (Table „Load Column Data“ (page 9) direct the Column Data bits, D4–D0 (Table „Load Column Data“ (page 9) to specific RAM location. Table „Character 'D'“ (page 8) shows the Row Address for the example character 'D.' Column data is written and read asynchronously from the 200 bit RAM. Once loaded the internal oscillator and character multiplexer reads the data from the RAM. These characters are row strobed with column data as shown in Figures „Row and Column Location“ (page 9) and „Row Strobing“ (page 10). The character strobe rate is determined by the internal or user supplied external MUX Clock and the IC's ÷320 counter.

Character "D"

	Op code			Column Data					Hex
	D7	D6	D5	D4	D3	D2	D1	D0	
	C0	C1	C2	C3	C4				
Row 0	0	0	0	1	1	1	1	0	1E
Row 1	0	0	1	1	0	0	0	1	31
Row 2	0	1	0	1	0	0	0	1	51
Row 3	0	1	1	1	0	0	0	1	71
Row 4	1	0	0	1	1	1	1	0	9E

Loading Serial Character Data

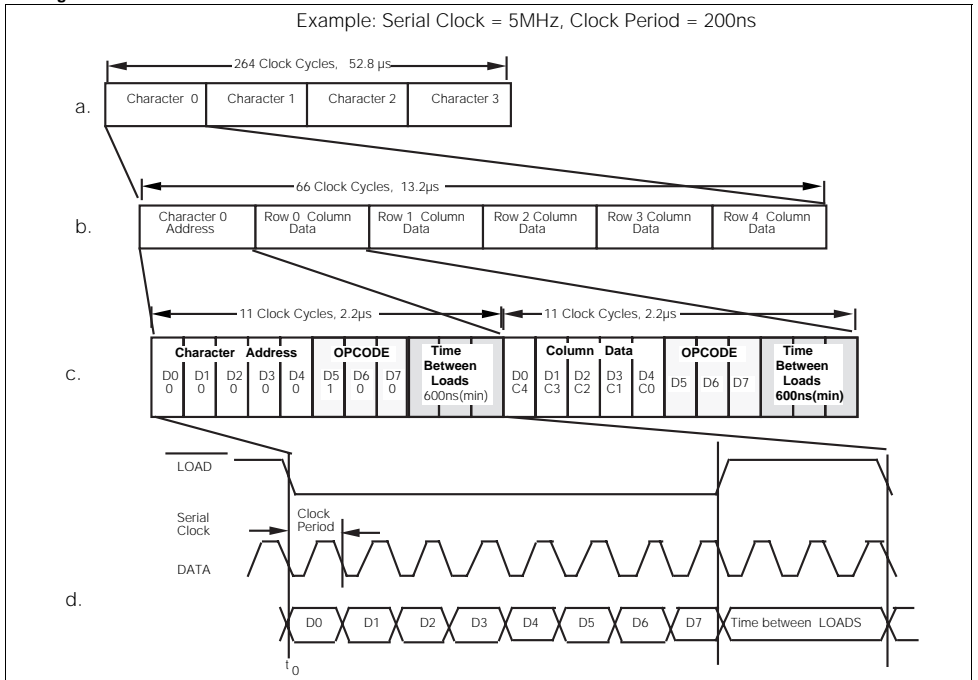

Load Character Address

Op code D7 D6 D5	Character Address D4 D3 D2 D1 D0	Hex	Operation Load
1 0 1	0 0 0 0 0	A0	Character 0
1 0 1	0 0 0 0 1	A1	Character 1
1 0 1	0 0 0 1 0	A2	Character 2
1 0 1	0 0 0 1 1	A3	Character 3

Load Column Data

Op code D7 D6 D5	Column Data D4 D3 D2 D1 D0	Operation Load
0 0 0	C0 C1 C2 C3 C4	Row 0
0 0 1	C0 C1 C2 C3 C4	Row 1
0 1 0	C0 C1 C2 C3 C4	Row 2
0 1 1	C0 C1 C2 C3 C4	Row 3
1 0 0	C0 C1 C2 C3 C4	Row 4

The user can activate four Control functions. These include: LED Brightness Level, Lamp Test, IC Power Down, or Display Clear. OPCODEs and five bit words are used to initiate these functions. The OPCODEs and Control Words for the Character Address and Loading Column Data are shown in Tables „Load Character Address“ ([page 9](#)) and „Load Column Data“ ([page 9](#)).

The user can select seven specific LED brightness levels, Table „Display Brightness“ ([page 9](#)). These brightness levels (in percentages of full brightness of the display) include: 100% (F0_{HEX}), 53% (F1_{HEX}), 40% (F2_{HEX}), 27% (F3_{HEX}), 20% (F4_{HEX}), 13% (F5_{HEX}), and 6.6% (F6_{HEX}). The brightness levels are controlled by changing the duty factor of the row strobe pulse.

Row and Column Location

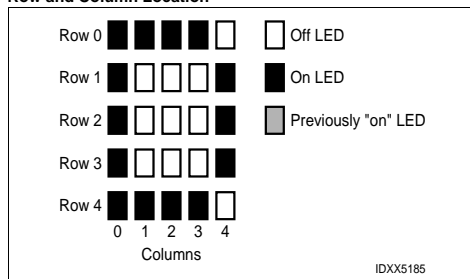

Display Brightness

Op code D7 D6 D5	Control Word D4 D3 D2 D1 D0	Hex	Operation Level
1 1 1	1 0 0 0 0	F0	100%
1 1 1	1 0 0 0 1	F1	53%
1 1 1	1 0 0 1 0	F2	40%
1 1 1	1 0 0 1 1	F3	27%
1 1 1	1 0 1 0 0	F4	20%
1 1 1	1 0 1 0 1	F5	13%
1 1 1	1 0 1 1 0	F6	6.6%

The SCDV554X offers a unique Display Power Down feature which reduces I_{CC} to less than 50 μ A. When FF_{HEX} is loaded, as shown in Table „Power Down“ ([page 9](#)), the display is set to 0% brightness and the internal multiplex clock is stopped. When in the Power Down mode data may still be written into the RAM. The display is reactivated by loading a new Brightness Level Control Word into the display.

Power Down

Op code D7 D6 D5	Control Word D4 D3 D2 D1 D0	Hex	Operation Level
1 1 1	1 1 1 1 1	FF	0% brightness

The Lamp Test is enabled by loading F8_{HEX}, Table „Lamp Test“ ([page 9](#)), into the serial shift register. This Control Word sets all of the LEDs to a 53% brightness level. Operation of the Lamp Test has no effect on the RAM and is cleared by loading a Brightness Control Word.

Lamp Test

Op code D7 D6 D5	Control Word D4 D3 D2 D1 D0	Hex	Operation Level
1 1 1	1 0 B B B		Lamp Test (OFF)
1 1 1	1 1 0 0 0	F8	Lamp Test (OFF)

The Software Clear (C0_{HEX}), given in Table „Software Clear“ ([page 9](#)), clears the Address Register and the RAM. The display is blanked and the Character Address Register will be set to Character 0. The internal counter and the Control Word Register are unaffected. The Software Clear will remain active until the next data input cycle is initiated.

Software Clear

Op code D7 D6 D5	Control Word D4 D3 D2 D1 D0	Hex	Operation Level
1 1 0	0 0 0 0 0	C0	CLEAR

Row Strobing

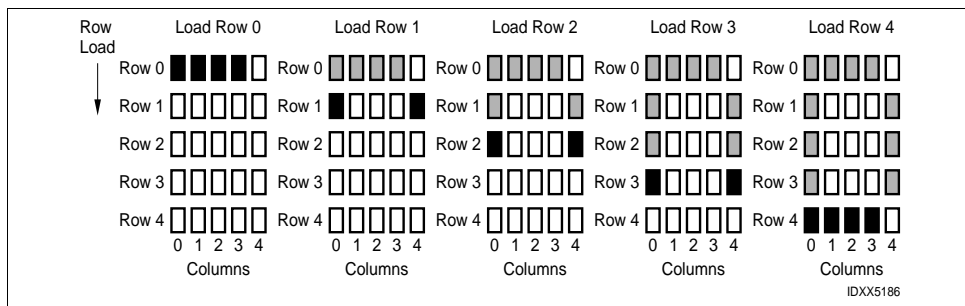

Multiplexer and Display Driver

The four characters are row multiplexed with RAM resident column data. The strobe rate is established by the internal or external MUX Clock rate. The MUX Clock frequency is divided by a 320 counter chain. This results in a typical strobe rate of 750 Hz. By pulling the Clock SEL line low, the display can be operated from an external MUX Clock. The external clock is attached to the CLK I/O connection (pin 8). The maximum external MUX Clock frequency should be limited to 1.0 MHz.

An asynchronous hardware Reset Pin is also provided. Bringing this pin low will clear the Character Address Register, Control Word Register, RAM, and blanks the display. This action leaves the display set at Character Address 0, and the Brightness Level set at 100%.

Electrical & Mechanical Considerations

Interconnect Considerations

Optimum product performance can be had when the following electrical and mechanical recommendations are adopted. The SCDV554X's IC is constructed in a high speed CMOS process, consequently high speed noise on the SERIAL DATA, SERIAL DATA CLOCK, LOAD and RESET lines may cause incorrect data to be written into the serial shift register. Adhere to transmission line termination procedures when using fast line drivers and long cables (> 10 cm).

Good digital grounds (pins 7 and 14) and power supply decoupling (pins 10, 11 and 12) will insure that I_{CC} (< 400 mA peak) switching currents do not generate localized ground bounce. Therefore it is recommended that each display package use a 0.1 μ F and 20 μ F capacitor between V_{CC} and ground.

When the internal MUX Clock is being used connect the \overline{CLKSEL} pin to V_{CC} . In those applications where RESET will not be connected to the system's reset control, it is recommended that this pin be connected to the center node of a series 0.1 μ F and 100 k Ω RC network. Thus upon initial power up the RESET will be held low for 10 ms allowing adequate time for the system power supply to stabilize.

ESD Protection

The input protection structure of the SCDV554X provides significant protection against ESD damage. It is capable of withstanding discharges greater than 2.0 kV. Take all the standard precautions, normal for CMOS components. These include properly grounding personnel, tools, tables, and transport carriers that come in contact with unshielded parts. If these conditions are not, or cannot be met, keep the leads of the device shorted together or the parts in anti-static packaging.

Soldering Considerations

The SCDV554X can be hand soldered with SN63 solder using a grounded iron set to 260°C.

Wave soldering is also possible following these conditions: Pre-heat that does not exceed 93°C on the solder side of the PC board or a package surface temperature of 85°C. Water soluble organic acid flux (except carboxylic acid) or rosin-based RMA flux without alcohol can be used.

Wave temperature of 245°C \pm 5°C with a dwell between 1.5 sec. to 3.0 sec. Exposure to the wave should not exceed temperatures above 260°C for five seconds at 1.59 mm (0.063") below the seating plane. The packages should not be immersed in the wave.

Post Solder Cleaning Procedures

The least offensive cleaning solution is hot D.I. water (60°C) for less than 15 minutes. Addition of mild saponifiers is acceptable. Do not use commercial dishwasher detergents.

For faster cleaning, solvents may be used. Exercise care in choosing solvents as some may chemically attack the nylon package. For further information refer to Appnotes 18 and 19 at www.osram-os.com

An alternative to soldering and cleaning the display modules is to use sockets. Naturally, 14 pin DIP sockets 7.62 mm (0.300") wide with 2.54 mm (0.100") centers work well for single displays. Multiple display assemblies are best handled by longer SIP sockets or DIP sockets when available for uniform package alignment. Socket manufacturers are Aries Electronics, Inc., Frenchtown, NJ; Garry Manufacturing, New Brunswick, NJ; Robison-Nugent, New Albany, IN; and Samtec Electronic Hardware, New Albany, IN.

For further information refer to Appnote 22 at www.osram-os.com

Optical Considerations

The 3.2 mm (0.123") high character of the SCDV554X gives readability up to five feet. Proper filter selection enhances readability over this distance.

Using filters emphasizes the contrast ratio between a lit LED and the character background. This will increase the discrimination of different characters. The only limitation is cost. Take into consideration the ambient lighting environment for the best cost/benefit ratio for filters.

Incandescent (with almost no green) or fluorescent (with almost no red) lights do not have the flat spectral response of sunlight. Plastic band-pass filters are an inexpensive and effective way to strengthen contrast ratios. The SCDV5540/2 are red/super-red displays and should be matched with long wavelength pass filter in the 570 nm to 590 nm range. The SCDV5543/4 should be matched with a yellow-green band-pass filter that peaks at 565 nm. For displays of multiple colors, neutral density grey filters offer the best compromise.

Additional contrast enhancement is gained by shading the displays. Plastic band-pass filters with built-in louvers offer the next step up in contrast improvement. Plastic filters can be improved

further with anti-reflective coatings to reduce glare. The trade-off is fuzzy characters. Mounting the filters close to the display reduces this effect. Take care not to overheat the plastic filter by allowing for proper air flow.

Optimal filter enhancements are gained by using circular polarized, anti-reflective, band-pass filters. The circular polarizing further enhances contrast by reducing the light that travels through the filter and reflects back off the display to less than 1%.

Several filter manufacturers supply quality filter materials. Some of them are: Panelgraphic Corporation, W. Caldwell, NJ; SGL Homalite, Wilmington, DE; 3M Company, Visual Products Division, St. Paul, MN; Polaroid Corporation, Polarizer Division, Cambridge, MA; Marks Polarized Corporation, Deer Park, NY; Hoya Optics, Inc., Fremont, CA.

One last note on mounting filters: recessing displays and bezel assemblies is an inexpensive way to provide a shading effect in overhead lighting situations. Several Bezel manufacturers are: R.M.F. Products, Batavia, IL; Nobex Components, Griffith Plastic Corp., Burlingame, CA; Photo Chemical Products of California, Santa Monica, CA; I.E.E.-Atlas, Van Nuys, CA.

SCDV Interface with Siemens/Intel 8031 Microprocessor (using serial port in mode 0)

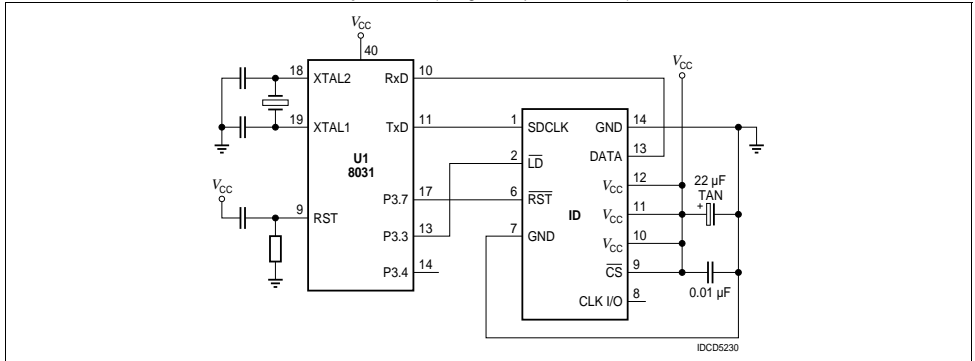

SCDV Interface with Siemens/Intel 8031 Microprocessor (using one bit of parallel port as serial input)

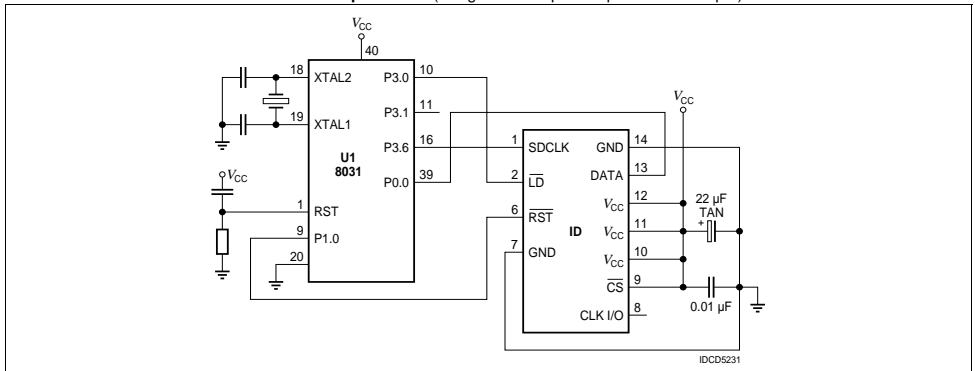

SCDV5540, SCDV5541, SCDV5542, SCDV5543, SCDV5544

Microprocessor Interface

The microprocessor interface is through the serial port, SPI port or one out of eight data bits on the eight bit parallel port and also control lines \overline{SDCLK} and \overline{LOAD} .

Power Up Sequence

Upon power up display will come on at random. Thus the display should be reset at power-up. The reset will set the Address Register to Digit 0, User RAM is set to 0 (display blank) the Control Word is set to 0 (100% brightness with Lamp Test off) and the internal counters are reset.

Cascading Multiple Displays

Multiple displays can be cascaded using the \overline{CLKSEL} and $\overline{CLK I/O}$ pins as shown below. The display designated as the Master Clock source should have its \overline{CLKSEL} pin tied high and the slaves should have their \overline{CLKSEL} pins tied low. All $\overline{CLK I/O}$ pins should be tied together. One display $\overline{CLK I/O}$ can drive 15 slave $\overline{CLK I/O}$ s. Use \overline{RST} to synchronize all display counters.

SCDV554X Interface with Motorola 68HC05C4 Microprocessor (using SPI port)

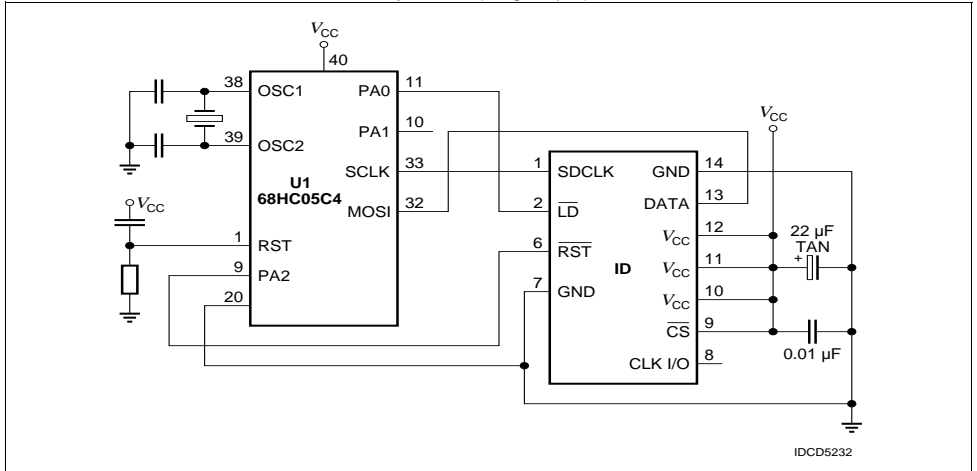

Cascading Multiple Displays

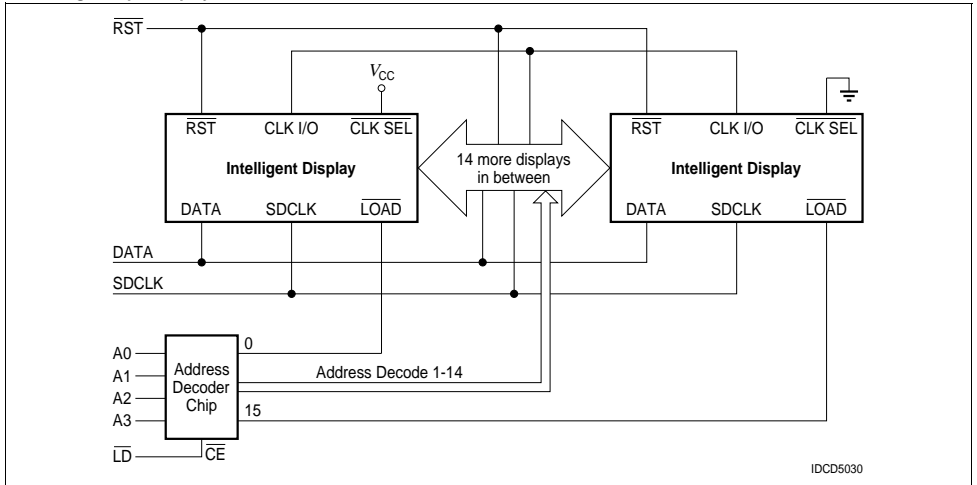

Loading Data Into the Display

Use following procedure to load data into the display:

1. Power up the display.
2. Bring $\overline{\text{RST}}$ low (600 ns duration minimum) to clear the Multiplex Counter, Address Register, Control Word Register, User Ram and Data Register. The display will be blank. Display brightness is set to 100%.
3. If a different brightness is desired, load the proper brightness opcode into the Control Word Register.
4. Load the Digit Address into the display.
5. Load display row and column data for the selected digit.
6. Repeat steps 4 and 5 for all digits.

Data Contents for the Display in a Vertical Format „↑AB↓“

Step	D7	D6	D5	D4	D3	D2	D1	D0	Function
A	1	1	0	0	0	0	0	0	CLEAR
B (optional)	1	1	1	1	0	B	B	B	BRIGHTNESS SELECT
1	1	0	1	0	0	0	0	0	DIGIT D0 SELECT
2	0	0	0	0	0	1	0	0	ROW 0 D0 (↑)
3	0	0	1	0	1	1	1	0	ROW 1 D0 (↑)
4	0	1	0	1	0	1	0	1	ROW 2 D0 (↑)
5	0	1	1	0	0	1	0	0	ROW 3 D0 (↑)
6	1	0	0	0	0	1	0	0	ROW 4 D0 (↑)
7	1	0	1	0	0	0	0	1	DIGIT D1 SELECT
8	0	0	0	0	0	1	0	0	ROW 0 D1 (A)
9	0	0	1	0	1	0	1	0	ROW 1 D1 (A)
10	0	1	0	1	1	1	1	1	ROW 2 D1 (A)
11	0	1	1	1	0	0	0	1	ROW 3 D1 (A)
12	1	0	0	1	0	0	0	1	ROW 4 D1 (A)
13	1	0	1	0	0	0	1	0	DIGIT D2 SELECT
14	0	0	0	1	1	1	1	0	ROW 0 D2 (B)
15	0	0	1	0	1	0	0	1	ROW 1 D2 (B)
16	0	1	0	0	1	1	1	0	ROW 2 D2 (B)
17	0	1	1	0	1	0	0	1	ROW 3 D2 (B)
18	1	0	0	1	1	1	1	0	ROW 4 D2 (B)
19	1	0	1	0	0	0	1	1	DIGIT D3 SELECT
20	0	0	0	0	0	1	0	0	ROW 0 D3 (↓)
21	0	0	1	0	0	1	0	0	ROW 1 D3 (↓)
22	0	1	0	1	0	1	0	1	ROW 2 D3 (↓)
23	0	1	1	0	1	1	1	0	ROW 3 D3 (↓)
24	1	0	0	0	0	1	0	0	ROW 4 D3 (↓)

Note:

If the display is already reset at Power Up, there is no need for Software Clear.

User Definable Character Set Examples*

Upper and Lower Case Alphabets

HEX CODE		HEX CODE		HEX CODE		HEX CODE		HEX CODE		HEX CODE		HEX CODE		HEX CODE		HEX CODE		HEX CODE	
04	■	1E	■	0F	■	1E	■	1F	■	1F	■	0F	■	11	■	0E	■		
2A	■	29	■	30	■	29	■	3D	■	30	■	30	■	31	■	24	■		
5F	■	4E	■	50	■	49	■	5E	■	5E	■	53	■	5F	■	44	■		
71	■	69	■	70	■	69	■	71	■	71	■	71	■	71	■	64	■		
91	■	9E	■	8F	■	9E	■	9F	■	90	■	8F	■	91	■	8E	■		
01	■	13	■	10	■	11	■	11	■	0E	■	1E	■	0C	■	1E	■	1E	■
21	■	34	■	30	■	3B	■	39	■	31	■	31	■	3E	■	32	■	31	■
41	■	58	■	50	■	55	■	55	■	51	■	5E	■	56	■	56	■	5E	■
71	■	74	■	71	■	71	■	73	■	71	■	71	■	72	■	74	■	74	■
8E	■	93	■	9F	■	91	■	91	■	8E	■	90	■	8D	■	92	■		
0F	■	1F	■	11	■	11	■	11	■	11	■	11	■	1F	■				
30	■	24	■	31	■	31	■	31	■	22	■	2A	■	44	■				
4E	■	44	■	51	■	51	■	55	■	44	■	44	■	44	■				
61	■	64	■	71	■	6A	■	7B	■	6A	■	64	■	68	■				
9E	■	84	■	8E	■	84	■	91	■	91	■	84	■	9F	■				
00	■	10	■	00	■	00	■	00	■	04	■	00	■	10	■	04	■		
2E	■	30	■	2F	■	21	■	2E	■	2A	■	2F	■	30	■	20	■		
52	■	5E	■	50	■	4F	■	5F	■	48	■	50	■	56	■	4C	■		
72	■	71	■	70	■	70	■	70	■	7C	■	73	■	79	■	64	■		
8D	■	8F	■	8F	■	8F	■	8E	■	88	■	8F	■	91	■	8E	■		
00	■	10	■	0C	■	00	■	00	■	00	■	00	■	00	■	00	■		
26	■	30	■	2A	■	2A	■	36	■	2E	■	3E	■	2F	■	33	■		
42	■	56	■	44	■	55	■	59	■	51	■	51	■	51	■	54	■		
72	■	78	■	64	■	71	■	71	■	71	■	70	■	8F	■	78	■		
96	■	8E	■	91	■	91	■	91	■	8E	■	90	■	81	■	90	■		
00	■	08	■	00	■	00	■	00	■	00	■	00	■	00	■				
23	■	3C	■	32	■	31	■	31	■	32	■	31	■	3E	■				
44	■	48	■	52	■	51	■	55	■	4C	■	4A	■	44	■				
62	■	6A	■	72	■	6A	■	7B	■	6C	■	64	■	68	■				
84	■	84	■	8D	■	84	■	91	■	92	■	98	■	9E	■				

IDCS5089

Numerals and Punctuation

HEX CODE		HEX CODE		HEX CODE		HEX CODE		HEX CODE		HEX CODE		HEX CODE		HEX CODE		HEX CODE		HEX CODE	
0E	■	04	■	1E	■	1E	■	06	■	1F	■	06	■	1F	■	0E	■		
33	■	2C	■	21	■	21	■	2A	■	30	■	28	■	22	■	4E	■		
55	■	44	■	46	■	4E	■	5F	■	5E	■	5E	■	68	■	88	■		
79	■	64	■	6F	■	6F	■	62	■	61	■	71	■	68	■	88	■		
8E	■	8E	■	98	■	9E	■	82	■	9E	■	8E	■	88	■	8E	■		
0E	■	0A	■	0F	■	09	■	19	■	08	■	0C	■	02	■	08	■		
31	■	3F	■	3A	■	29	■	3A	■	34	■	2C	■	24	■	24	■		
4F	■	4A	■	4E	■	5C	■	44	■	4D	■	44	■	44	■	44	■		
62	■	7F	■	65	■	68	■	6B	■	72	■	64	■	64	■	64	■		
8C	■	8A	■	9E	■	9F	■	93	■	8D	■	80	■	82	■	88	■		
0C	■	04	■	00	■	00	■	00	■	01	■	04	■	0A	■	07	■		
2C	■	24	■	2C	■	20	■	20	■	22	■	24	■	2A	■	24	■		
48	■	5F	■	40	■	5F	■	40	■	44	■	44	■	40	■	44	■		
64	■	64	■	64	■	60	■	6C	■	68	■	60	■	60	■	64	■		
80	■	84	■	88	■	80	■	8C	■	90	■	84	■	80	■	87	■		
10	■	1C	■	0E	■	00	■	0C	■	0C	■	02	■	00	■	08	■		
28	■	24	■	35	■	20	■	2C	■	20	■	24	■	3F	■	24	■		
44	■	44	■	57	■	40	■	40	■	4C	■	48	■	40	■	42	■		
62	■	64	■	70	■	60	■	6C	■	64	■	64	■	7F	■	64	■		
81	■	9C	■	8E	■	9F	■	88	■	88	■	82	■	80	■	84	■		
0E	■	06	■	0C	■	04	■	11	■	15	■	04	■	08	■				
31	■	24	■	24	■	24	■	2A	■	2E	■	35	■	35	■				
42	■	48	■	42	■	40	■	44	■	5F	■	42	■	42	■				
64	■	64	■	64	■	64	■	6E	■	60	■	60	■	60	■				
88	■	86	■	8C	■	84	■	84	■	95	■	80	■	80	■				

IDCS5090

*CAUTION: No more than 128 LEDs "on" at one time at 100% brightness.

SCDV5540, SCDV5541, SCDV5542, SCDV5543, SCDV5544

User Definable Character Set Examples* (continued)

Scientific Notations, etc.

HEX CODE	HEX CODE	HEX CODE	HEX CODE	HEX CODE	HEX CODE	HEX CODE	HEX CODE	HEX CODE	HEX CODE	HEX CODE	HEX CODE	HEX CODE	HEX CODE
06	04	1F	1F	0E	0D	0C	0E	00	24	4A	71	9F	
2E	24	20	20	20	32	32	32	24	4A	71	9F		
5E	48	59	59	56	4A	56	4E	4A	71	9F			
6E	71	75	75	79	64	72	71	6A	71	9F			
8E	8E	93	93	91	8A	8D	9E	8E	71	9F			
10	0E	10	09	08	04	0E	0E	0F	32	52	72	8C	
3C	31	28	28	29	2E	2E	31	2E	32	52	72	8C	
52	5F	44	44	49	54	55	51	5A	6A	7A	8A	8C	
72	71	6A	6A	6E	64	6E	6A	6A	7A	8A	8C		
81	8E	91	91	90	84	84	9B	8A	7A	8A	8C		
1F	18	1C	12	06	07	1C	0F	04	2E	5F	7F	88	
28	24	28	28	21	22	22	28	28	34	44	5F	7F	88
44	48	44	44	5A	59	5C	5C	48	48	5F	7F	88	
68	7C	78	78	67	66	60	60	78	78	6E	8E	80	
9F	80	80	80	80	80	80	80	88	88	80	80	80	
00	04	0E	04	0E	00	00	04	04	2E	5F	7F	88	
24	2E	3F	3E	2F	2E	3F	3F	2E	5F	7F	88		
4E	5F	4E	4E	5F	4E	5F	4E	5F	4E	5F	7F	88	
7F	8E	64	64	7E	6E	7F	6E	7F	6E	7F	88		
8E	84	80	84	84	8E	8E	80	84	84	84	84	84	
04	04	1F	08	0A	15	1F	00	0E	2E	5F	7F	88	
22	28	31	2C	35	35	35	3F	3F	4A	5F	7F	88	
5F	5F	51	4A	4A	55	5F	5F	5F	6A	7A	8A	8C	
62	68	71	78	75	6A	75	7C	7C	7C	8A	8A	8C	
84	84	9F	98	98	8A	9F	9F	80	80	80	80	80	
00	00	00	00	00	0C	15							
27	3C	20	20	20	23	2E							
4F	5F	40	40	40	5F	5C							
78	63	60	60	67	7F	7C							
9C	87	83	9F	9F	9F	9C							

IDCS5091

Foreign Characters

HEX CODE	HEX CODE	HEX CODE	HEX CODE	HEX CODE	HEX CODE	HEX CODE	HEX CODE	HEX CODE	HEX CODE	HEX CODE	HEX CODE	HEX CODE	HEX CODE
1F	1F	01	04	03	02	08	1F	02	02	02	02	02	02
21	21	22	3F	03	3F	3F	21	3F	3F	3F	3F	3F	3F
46	46	51	51	44	46	49	45	45	51	51	51	51	51
62	64	6A	61	64	6A	6A	67	67	6C	6C	6C	6C	6C
84	84	82	86	9F	92	88	8C	8C	8C	8C	8C	8C	8C
06	04	0F	08	0F	0A	19	0F	01	01	01	01	01	01
3F	3F	29	2F	21	21	29	29	3E	3E	3E	3E	3E	3E
49	44	51	52	41	4A	59	55	42	42	42	42	42	42
69	7F	61	62	61	62	62	63	7F	7F	7F	7F	7F	7F
92	84	8C	82	9F	8C	9C	8C	8C	8C	8C	8C	8C	8C
15	0E	08	04	0E	04	04	04	04	04	04	04	04	04
35	20	28	3F	20	21	21	3E	24	22	22	22	22	22
55	5F	4C	44	40	4A	44	44	44	51	51	51	51	51
62	64	6A	64	60	64	6E	6E	68	71	71	71	71	71
8C	98	90	98	9F	9A	9E	90	90	91	91	91	91	91
10	1F	0E	04	01	1F	1E	1F	0E	0E	0E	0E	0E	0E
3F	21	20	28	21	22	28	28	20	20	20	20	20	20
50	41	4E	51	4A	5F	42	42	5F	5F	5F	5F	5F	5F
70	62	60	61	64	62	62	62	62	61	61	61	61	61
8F	8C	8F	81	8A	87	8F	8F	8F	8F	8F	8F	8F	8F
12	04	1E	0F	0F	0F	0F	00	08	08	08	08	08	08
32	34	25	34	30	33	34	2A	24	24	24	24	24	24
52	64	4F	5F	4F	55	57	5F	5F	5F	5F	5F	5F	5F
64	75	74	74	64	79	74	74	72	72	72	72	72	72
88	96	8F	97	98	8E	8F	8B	8B	8B	8B	8B	8B	8B
0A	02	04	0A	02	02	04	04	04	04	04	04	04	04
2E	24	2A	34	24	24	2A	2A	2A	2A	2A	2A	2A	2A
51	4C	4E	52	51	51	51	51	51	51	51	51	51	51
7F	64	71	7A	71	71	71	71	71	71	71	71	71	71
91	8E	8E	96	8E	8E	8E	8E	8E	8E	8E	8E	8E	8E

IDCS5092

*CAUTION: No more than 128 LEDs "on" at one time at 100% brightness.

Revision History: 2006-01-23

Previous Version: 2005-01-10

Page	Subjects (major changes since last revision)	Date of change
all	Lead free device	2006-01-23

Published by
OSRAM Opto Semiconductors GmbH
 Wernerwerkstrasse 2, D-93049 Regensburg
www.osram-os.com
 © All Rights Reserved.

Attention please!

The information describes the type of component and shall not be considered as assured characteristics. Terms of delivery and rights to change design reserved. Due to technical requirements components may contain dangerous substances. For information on the types in question please contact our Sales Organization. If printed or downloaded, please find the latest version in the Internet.

Packing

Please use the recycling operators known to you. We can also help you – get in touch with your nearest sales office. By agreement we will take packing material back, if it is sorted. You must bear the costs of transport. For packing material that is returned to us unsorted or which we are not obliged to accept, we shall have to invoice you for any costs incurred.

Components used in life-support devices or systems must be expressly authorized for such purpose! Critical components¹⁾ may only be used in life-support devices or systems²⁾ with the express written approval of OSRAM OS.

- ¹⁾ A critical component is a component used in a life-support device or system whose failure can reasonably be expected to cause the failure of that life-support device or system, or to affect its safety or the effectiveness of that device or system.
- ²⁾ Life support devices or systems are intended (a) to be implanted in the human body, or (b) to support and/or maintain and sustain human life. If they fail, it is reasonable to assume that the health and the life of the user may be endangered.